

NEW

# NGR-21-62H

## GLASS DOOR MERCHANDISER

Ideal for cafés, grocery & convenience stores

**NEW AIR**  
REFRIGERATION



### FEATURES

Side LED interior lights

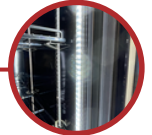

Black interior and exterior

Adjustable & removable  
epoxy-coated shelves

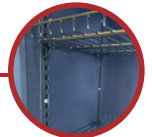

Low-E (energy-efficient low-emissivity)  
double tempered glass door

Self-closing door with lock



Casters & stabilizing feet

### OPTIONAL FEATURE

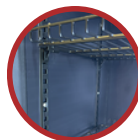

Shelves

# SPECIFICATIONS

Capacity (Cu. ft)	7.6/8
Capacity (Liters)	217/230
Exterior Dimensions (in)	21" (w) x 20.75" (d) x 62.25" (h)
Interior Dimensions (in)	18" (w) x 16.25" (d) x 46.25" (h)
Packaging Dimensions (in)	24.25" (w) x 23" (d) x 64.25" (h)
Net / Gross Weight (lb)	110/124
Doors	1
Casters	4
Stabilizing Feet	4
Adjustable shelves	3
Shelf dimensions	17.25" (w) x 14" (d)
Temperature	(0°C) - (10°C)
Refrigerant (CFC-Free)	R600a
Amperage (A)	2
Voltage (V)	110V/60Hz
Plug Type	NEMA 5-15P

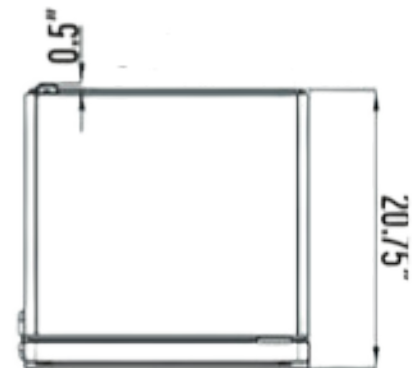
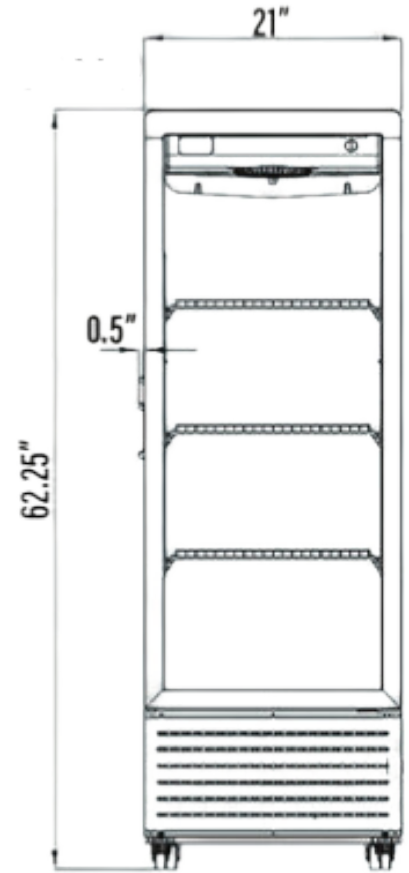

\*Design and specifications can change without prior notice for product improvement

CUSTOMER SUPPORT



1-800-567-3620



NEWAIRREFRIGERATION.CA

