

NEW

NGR-17-77H

GLASS DOOR MERCHANDISER

Ideal for cafés, grocery & convenience stores

NEW AIR
REFRIGERATION



FEATURES

Side LED interior lights



Black interior and exterior

Adjustable & removable
epoxy-coated shelves

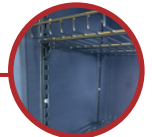

Low-E (energy-efficient low-emissivity)
double tempered glass door

Self-closing door with lock



Casters & stabilizing feet

OPTIONAL FEATURE

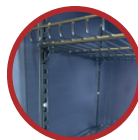

Shelves

SPECIFICATIONS

Capacity (Cu. ft)	7.6/8
Capacity (Liters)	217/229
Exterior Dimensions (in)	16.5" (w) x 20.75" (d) x 77.25" (h)
Interior Dimensions (in)	13.5" (w) x 16.25" (d) x 61.25" (h)
Packaging Dimensions (in)	19.75" (w) x 23" (d) x 79.25" (h)
Net / Gross Weight (lb)	110/124
Doors	1
Casters	4
Stabilizing Feet	4
Adjustable shelves	5
Shelf dimensions	12.5" (w) x 14" (d)
Temperature	(0°C) - (10°C)
Refrigerant (CFC-Free)	R600a
Amperage (A)	2
Voltage (V)	110V/60Hz
Plug Type	NEMA 5-15P

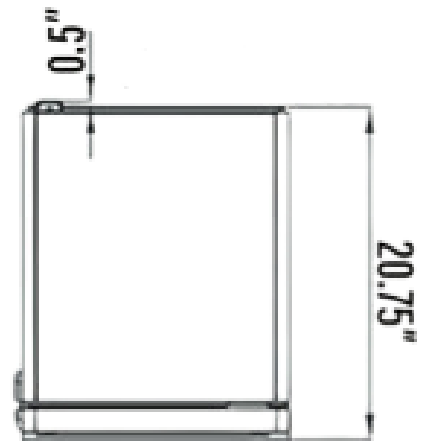
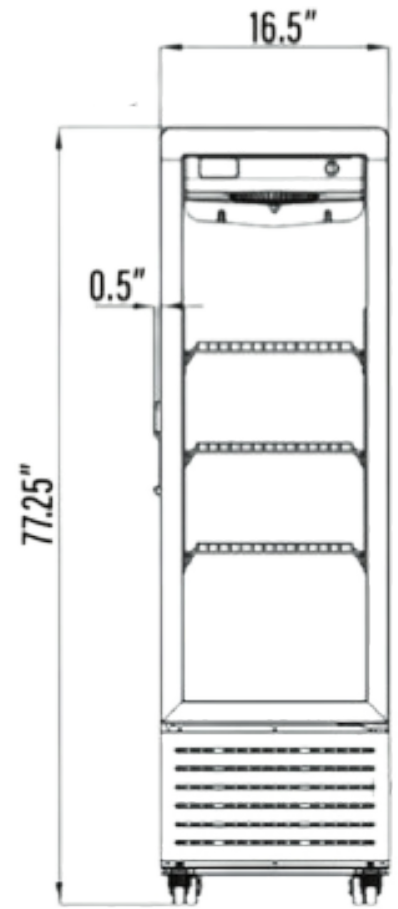

*Design and specifications can change without prior notice for product improvement

CUSTOMER SUPPORT



1-800-567-3620



NEWAIRREFRIGERATION.CA

