



FOOD EQUIPMENT

SERVING THE FOOD INDUSTRY SINCE 1951

TABLETOP PREMIUM EUROPEAN BAND SAWS

ITEM: 10275
MODEL: BS-IT-1981-S

ITEM: 10276
MODEL: BS-IT-1651

ITEM: 10277
MODEL: BS-IT-1981



**CUT SLABS OF MEAT
QUICKLY, EASILY, AND PRECISELY**

Omcan's Tabletop European Band Saws are designed for ease of use. The wheels, guides, and tables are quickly removed without tools. The anodized aluminium chassis and stainless steel table assembly affords quick clean up. The BS-IT-1651 and BS-IT-1981 feature fixed tables. The BS-IT-1981-S features an oversized table that slides effortlessly.



WARRANTY
PARTS AND LABOR



Only applies
to item 10276

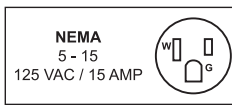

Authorized Dealer

- A must in a modern butcher shop, because of the first-class precision in cutting meat with bones, whether fresh or frozen, poultry, and fish.
- They guarantee high performance; extremely easy to use and easy to remove components for easy cleaning.
- Hard, anti-wear, stainless metal for a straighter blade cutting-edge and to avoid cross cutting.
- Safety switch start is possible only when the door is closed.
- Switch and motor are sealed off from water cleaning areas.
- Preloaded bladed fastener: by rotating the lever, it brings the blade to the right tension.
- Stainless steel table requires no tools to take it apart giving easy access for perfect cleaning.
- All inside surfaces are coated with an anti-stick material which is resistant to acid and meat justice.

All inside surfaces are coated with an anti-stick material. It is very easy to clean because there are no spaces or grooves where the bone dust can get caught or stuck.

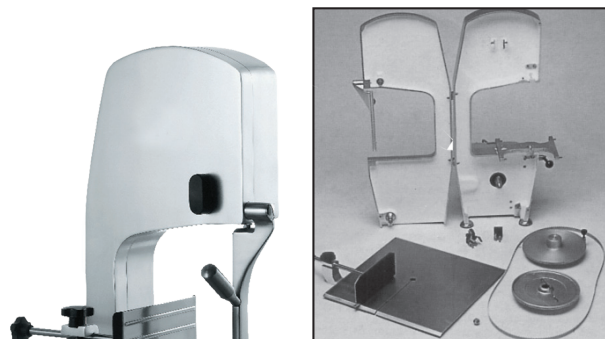

TECHNICAL DRAWINGS AND DIMENSIONS

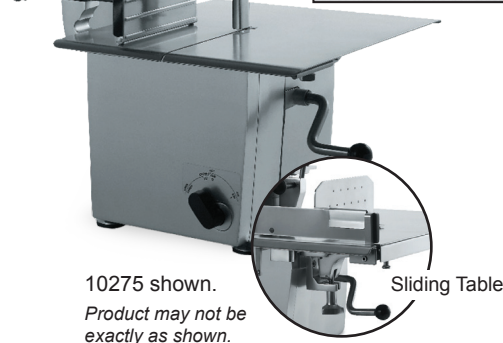
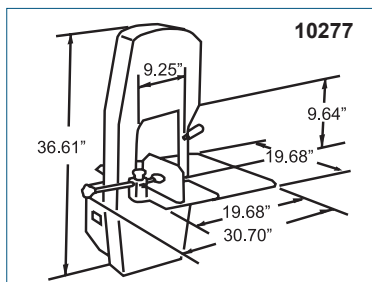
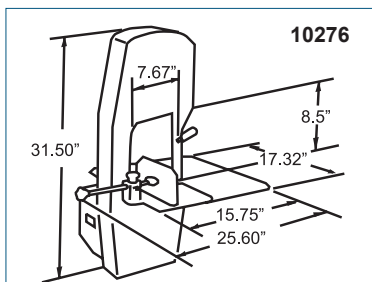

TECHNICAL SPECIFICATIONS

1.2 HP PREMIUM EUROPEAN BANDSAW WITH 65" BLADE LENGTH

1.5 HP PREMIUM EUROPEAN BANDSAW WITH 78" BLADE LENGTH

ITEM NUMBER	*10276	10277
MODEL	BS-IT-1651	BS-IT-1981
BLADE LENGTH	65" / 1651 mm	78" / 1981 mm
CUTTING CAPACITY (H*W)	11" x 8" / 279 x 203 mm	11" x 9.25" / 279 x 235 mm
POWER	1.2 HP / 0.90 kW	1.5 HP / 1.12 kW
ELECTRICAL	110V / 60Hz / 1Ph	110V / 60Hz / 1Ph
WEIGHT	97 lbs. / 44 kg.	123 lbs. / 56 kg.
PACKAGING WEIGHT	110 lbs. / 50 kg.	133 lbs. / 60 kg.
DIMENSIONS (DWH)	25.60" x 17.32" x 31.50" / 650 x 440 x 800 mm	30.70" x 19.68" x 36.61" / 780 x 500 x 930 mm
PACKAGING DIMENSIONS	30" x 24" x 38" / 762 x 610 x 965 mm	35" x 24" x 44" / 889 x 610 x 1118



WARRANTY
PARTS AND LABOR



NEMA
5-15
125 VAC / 15 AMP



OMCAN INC.

Telephone: 1-800-465-0234
Fax: (905) 607-0234
Email: sales@omcan.com
Website: www.omcan.com



Follow us to keep up to date with the latest news and offers



- Sliding semi-plate instead of a fixed plate.
- Stainless steel table sliding on ball bearings to make your work effortless, giving you an unusual cutting precision for any kind of meat either frozen or fresh poultry, fish, etc.
- Side pannel is equipped with a large thumb guard and has a useful end grip sliding along it.
- In case of large parts, the tables can easily be locked in.
- Finish: Anodized aluminium alloy, stainless-steel and food-acid resistant
- Cleaning: All inside surfaces are rounded, smooth and coated with a non-stick plastic material, for easy cleaning.

All inside surfaces are coated with an anti-stick material. It is very easy to clean because there are no spaces or grooves where the bone dust can get caught or stuck.

TECHNICAL DRAWING AND DIMENSIONS

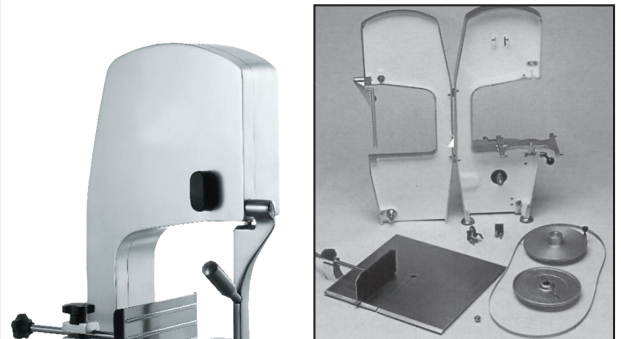
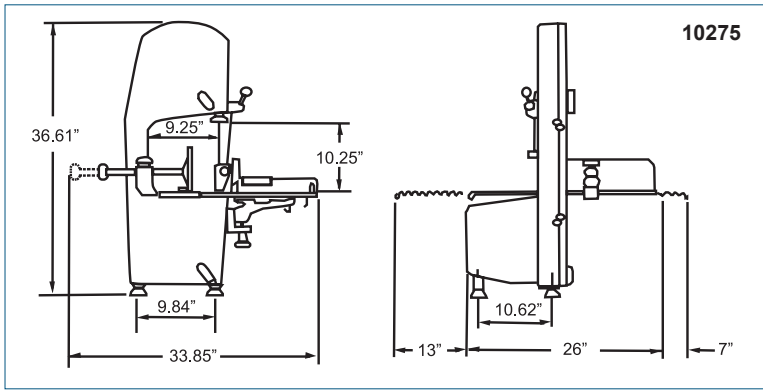

10275 shown.
 Product may not be exactly as shown.
 Sliding Table

TECHNICAL SPECIFICATION

1.5 HP PREMIUM EUROPEAN BANDSAW WITH 78" BLADE LENGTH AND SLIDING TABLE

ITEM NUMBER	10275
MODEL	BS-IT-1981-S
BLADE LENGTH	78" / 1981 mm
CUTTING CAPACITY (H*W)	11" x 9.25" / 279 x 235 mm
POWER	1.5 HP / 1.12 kW
ELECTRICAL	110V / 60Hz / 1Ph
WEIGHT	167 lbs. / 76 kg.
PACKAGING WEIGHT	175 lbs. / 79 kg.
DIMENSIONS (DWH)	33.85" x 26" x 36.61" / 860 x 660 x 930 mm
PACKAGING DIMENSIONS	38" x 30" x 42" / 965 x 762 x 1067 mm

1 YEAR WARRANTY
 PARTS AND LABOR

MADE IN ITALY





OMCAN INC.
 Telephone: 1-800-465-0234
 Fax: (905) 607-0234
 Email: sales@omcan.com
 Website: www.omcan.com



Follow us to keep up to date with the latest news and offers

