

VENEZIA ESPRESSO GRINDERS

Project	Date	Models	VGT, VGA, VGHDA	Item#	Quantity
---------	------	--------	-----------------	-------	----------



model VGA

Features

- Precision control grinder.
- Micro 'grind control' adjustment - an exclusive adjustment system that gives the operator infinite control over grind settings. No more preset 'clicks' for grind settings.
- Cast aluminum frame ensures perfect grind head alignment.
- Stroke counter indicates the number of cups of espresso that has been served.
- Precision machine burrs for exceptional grinding.

Models & Dimensions

Venezia Espresso Grinders

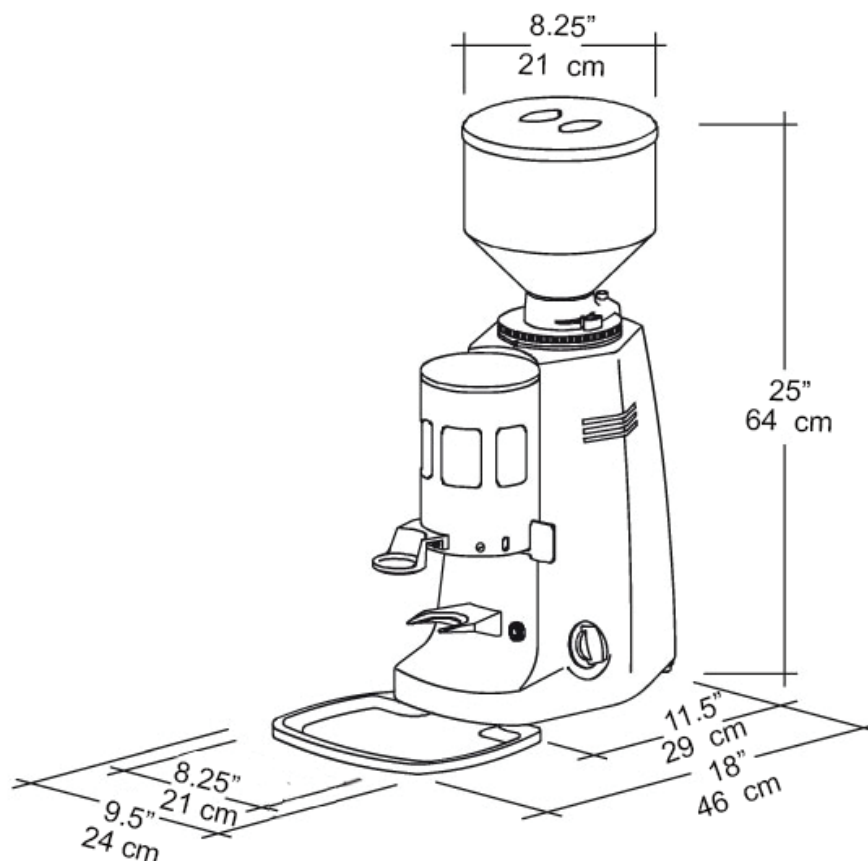

model VGHDA

Specifications

Model	Description	Bean Capacity	Ground Espresso Capacity	Electrical	Product Dimensions (H x W X D)	Ship Weight
VGT (077800L)	Espresso grinder with manual timer and 0.5 HP. Grinding blades: 2.5" (6.4 cm) diameter. Grinding speed: 1600 rpm.	2.7 lbs. (1.2 kg)	0.6 lbs. (0.3 kg)	120V / 350W 2.9 A / 1 Ph	24" x 9.5" x 16.5" (61 cm x 24 cm x 42 cm)	31 lbs. (14 kg)
VGA (077810L)	Espresso grinder with automatic timer and 0.5 HP. Grinding blades: 2.5" (6.4 cm) diameter. Grinding speed: 1600 rpm.	2.7 lbs. (1.2 kg)	0.6 lbs. (0.3 kg)	120V / 350W 2.9 A / 1 Ph	24" x 9.5" x 16.5" (61 cm x 24 cm x 42 cm)	31 lbs. (14 kg)
VGHDA (077820L)	Heavy duty espresso grinder with automatic timer and 1 HP. Grinding blades: 3.25" (8.3") diameter. Grinding speed: 1600 rpm.	4 lbs. (1.8 kg)	0.8 lbs. (0.4 kg)	120V / 650W 5.4 A / 1 Ph	25" x 9.5" x 18" (64 cm x 24 cm x 45.5 cm)	44 lbs. (20 kg)

Electrical: NEMA 5-15P line cord included.

Dose adjustment: 5.5g - 9g.

