



Undercounter ice maker - Sprayer system

Hotel	████████████████████
Restaurant	██████████████████
Fast food	██████████████
Bar	████████████████████
Disco	████████████████████
Fish market	██████████████████
Supermarket	██████████████████
Medical & SPA	██████████████████
Industry	██████████████

► Features & Plus

- Compact and crystal cube
- AISI 304 SS Scotch Brite finish
- Tropical class +43°C
- Adjustable Stainless Steel feet
- Air cooling system
- Easy cleanable internal rounded surfaces
- HCFC-Free insulated storage
- RoHS Free
- Disappearing insulated door
- Electromechanical operation
- ON-OFF rocker switch



AISI 304 SS Scotch Brite finish



Adjustable Stainless Steel feet



Easy cleanable internal rounded surfaces



Disappearing insulated door

► Available ice cube size

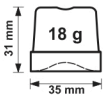

► Prod. 24h

	Air temp.	Water temp.	lbs
🌡️	50° F	50° F	150
	70° F	60° F	145
	90° F	70° F	120

Warranty

3 years parts & labor, 5 years on the compressor subject to limitations

► Certifications available for this model





Ice Cube

CB 640 2018



Undercounter ice maker - Sprayer system

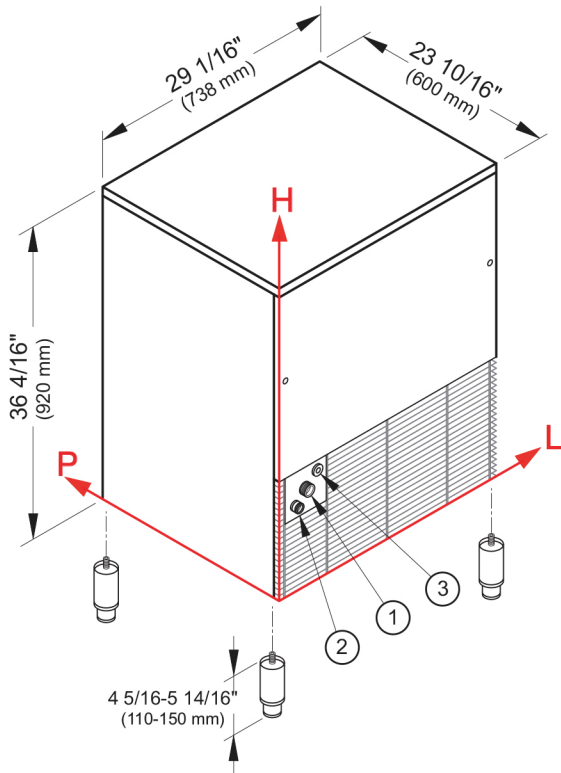

► Working conditions

- Location: **Indoor**

	Min	Max
Ambient temperature	+50° F	110° F
Water temperature	+37° F	+90° F
Voltage	-10%	+10%
Water inlet pressure	1bar (14 psi)	6bar (84 psi)

► Connections

All measures are referred to the rear bottom-left corner (L-H-Ø)

- ① Water in.: 4 9/16" - 11 4/16" - 3/4" ② Water out.: 2 2/16" - 9 10/16" - 15/16"
- ③ Electrical connections: 6 5/16" - 12 10/16"

► Technical information

Production in 24h *	120 lbs	Fuse	10 A
Store capacity, up to	88 lbs	Water consumption **	35 gal/100 lbs
Cooling system	A	Sizes (L-P-H in)	29 1/16 - 23 10/16 - 36 4/16
Kind of cube	A-18g	Sizes with pack (L-P-H in)	30 11/16 - 25 3/16 - 42 11/16
Refrigerant	R404A	Net weight	170 lbs
Standard voltage	115 V ~ 60Hz	Gross weight	196 lbs
Electrical consumption ***	450 W	Finish	AISI 304 stainless steel, scotch brite

All the technical information must be considered at the following conditions:

Sizes without feet

* Production at Ambient temperature +90° F / Water temperature +70° F

** Water consumption at Ambient temperature +70° F / Water temperature +60° F

*** Electrical consumption at ambient temperature +109° F

Models and specifications are subject to change without notice



CANADA
120 de la Barre
Boucherville, QC J4B 1K7

US
334 Cornelia, St. # 272
Plattsburgh, NY 12901
Tel.: 1 888-956-6866
Fax: 1 877-956-6867

www.eurodib.com
info@eurodib.com