



VACUUM PACKING MACHINE SU-6100GP+ 208-240/60/3

Double chamber vacuum packing machine. 100m³/h.



P/N. 1141072

- ✓ Working hours counter for oil changes.
- ✓ Safety system with protection against vacuum failure.
- ✓ NSF-listed.

INCLUDES

- ✓ Inert gas flush (G models).
- ✓ Bluetooth connectivity and connection for printer (P models).
- ✓ PLUS welding for retort pouches (+ models).
- ✓ BUSCH pump.
- ✓ Sensor Controls.
- ✓ 25 programmable settings.
- ✓ Vacuum PLUS: up to 10 seconds of extra vacuum pull.
- ✓ Soft air function.
- ✓ Clear methacrylate lid.
- ✓ "PAUSE" function.
- ✓ Liquid detection system.
- ✓ Dry oil cycle.
- ✓ NSF Approved.
- ✓ 4 filling plates.

ACCESSORIES

- Bag cutting kits
- Filling plates
- Liquid insert plates
- Vac-norm external vacuum kits
- Vac-norm containers
- Smooth bags for vacuum packing
- Thermal labels for CG2 / RB printer
- RB Desktop printer for SU vacuum packing machines *
- Thermal transfer labels for RB printer



SALES DESCRIPTION

High performance model with tilting cover, double chamber and 4 x 662 mm. sealing bars. 100 m³/h Busch vacuum pump. Vacuum controlled by sensor.

- ✓ Powered by Busch.
- ✓ Vacuum controlled by sensor.
- ✓ Vacuum PLUS.
- ✓ LCD colour screen: all information at a glance.
- ✓ Backlit touch keyboard.
- ✓ Programmable: 25-programme memory. Blocking option.
- ✓ "Pause" button.
- ✓ Phased vacuum programme.
- ✓ Detection of the evaporation of liquids.
- ✓ Double seal.
- ✓ Cordless sealing bar.
- ✓ Progressive decompression.
- ✓ Vac-Norm ready with Automatic decompression.
- ✓ Stainless steel body and chambers.
- ✓ Tilting cover made of thick, robust stainless steel.
- ✓ Dry-oil programme for drying the pump.



sammic | www.sammic.us
Food Service Equipment Manufacturer

usa@sammic.com
1225 Hartrey Avenue
60202-1056 Evanston, IL

phone +1 (224) 307-2232
toll free +1 844 275 3848



Project	Date
Item	Qty
Approved	

FOOD PRESERVATION AND SOUS-VIDE VACUUM PACKING MACHINES - "SENSOR ULTRA" LINE

product sheet updated 10/02/20



VACUUM PACKING MACHINE SU-6100GP+ 208-240/60/3

Double chamber vacuum packing machine. 100m³/h.



SPECIFICATIONS

Pump capacity: 3500 cf/h
 Bar length: 26" + 26"
 Total loading: 3 Hp
 Vacuum pressure (maximum): 0.5 mbar
 Electrical supply: 208 V-230 V / 60 Hz / 3 ~ (16 A)
 Plug: --

Internal dimensions

- ✓ Width: 26"
- ✓ Depth: 25.8"
- ✓ Height: 8"

External dimensions (WxDxH)

- ✓ Width: 65"
- ✓ Depth: 35"
- ✓ Height: 54"

Net weight: 794 lbs.

Noise level (1m.): 75 dB(A)
 Background noise: 32 dB(A)

Crated dimensions

38.6 x 67.7 x 50.4"
 Gross weight: 981.1 lbs.

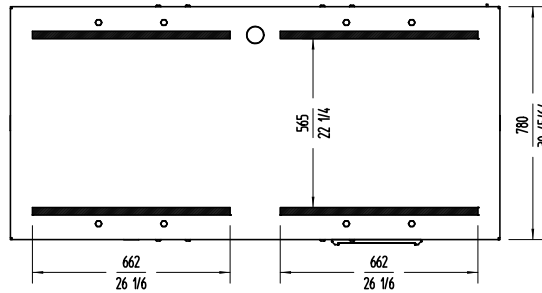
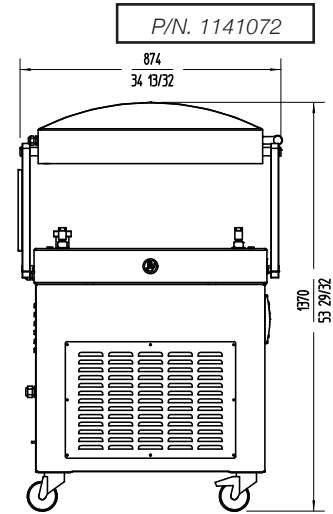
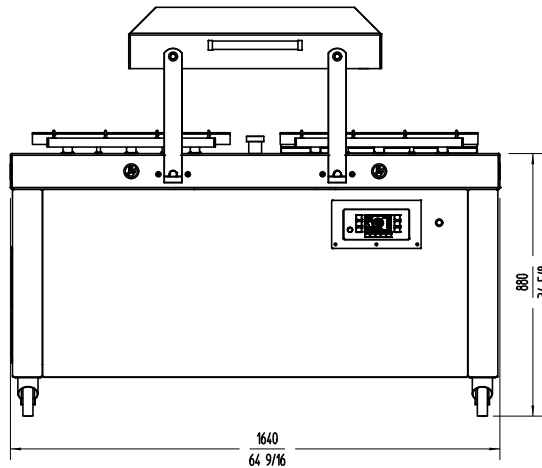

FOOD PRESERVATION AND SOUS-VIDE
 VACUUM PACKING MACHINES - "SENSOR ULTRA" LINE

sammic | www.sammic.us
 Food Service Equipment Manufacturer

usa@sammic.com
 1225 Hartrey Avenue
 60202-1056 Evanston, IL

phone +1 (224) 307-2232
 toll free +1 844 275 3848



Project	Date
Item	Qty
Approved	

product sheet
 updated 10/02/20