



# VACUUM PACKING MACHINE SE-316 120/50-60/1

Tabletop model. 16 m<sup>3</sup>/h. 320 mm.



Cód. 1140631



## FEATURES AND BENEFITS

- ✓ Powered by Busch.
- ✓ Vacuum controlled by sensor.
- ✓ Vacuum PLUS.
- ✓ Digital keyboard.
- ✓ Control panel equipped with display indicating the exact vacuum percentage.
- ✓ "Pause" button to marinate food.
- ✓ Safe liquid packing thanks to sensor control.
- ✓ Double seal.
- ✓ Cordless sealing bar.
- ✓ Bag-sealing programme.
- ✓ Pulse-controlled decompression.
- ✓ Vac-Norm ready with Automatic decompression.
- ✓ Stainless steel body and chamber. Deep-drawn chamber.
- ✓ Damped transparent lid of highly durable polycarbonate.
- ✓ Dry-oil programme for drying the pump.
- ✓ Working hours counter for oil changes.
- ✓ Safety system with protection against vacuum failure.
- ✓ NSF-listed model.

## SALES DESCRIPTION

320 mm. sealing bar.  
 16 m<sup>3</sup>/h Busch vacuum pump.  
 Vacuum controlled by sensor.

## INCLUDES

- ✓ Sensor Controls
- ✓ Up to 10 seconds of extra vacuum pull
- ✓ Soft air function
- ✓ Dry oil cycle
- ✓ BUSCH pump
- ✓ NSF Approved
- ✓ Clear methacrylate lid
- ✓ Filling plate



**sammic** | [www.sammic.us](http://www.sammic.us)  
**Food Service Equipment Manufacturer**

[usa@sammic.com](mailto:usa@sammic.com) phone +1 (224) 307-2232  
 1225 Hartrey Avenue toll free +1 844 275 3848  
 60202-1056 Evanston, IL



|          |      |
|----------|------|
| Project  | Date |
| Item     | Qty  |
| Approved |      |

FOOD PRESERVATION AND SOUS-VIDE  
 VACUUM PACKING MACHINES - "SENSOR" LINE

product sheet  
 updated 19/04/2018



# VACUUM PACKING MACHINE SE-316 120/50-60/1

Tabletop model. 16 m<sup>3</sup>/h. 320 mm.



Cód. 1140631

## SPECIFICATIONS

Pump capacity: 560 cf/h  
 Bar length: 12.6 "  
 Total loading: 0.5 Hp  
 Vacuum pressure (maximum): 2 mbar  
 Electrical supply: 120 V / 60 Hz / 1 ~ (8 A)

### Internal dimensions

- ✓ Width: 13 "
- ✓ Depth: 14 "
- ✓ Height: 6.1 "

### External dimensions (WxDxH)

- ✓ Width: 15 "
  - ✓ Depth: 18.3 "
  - ✓ Height: 16 "
- Net weight: 77 lbs.  
 Noise level (1m.): 75 dB(A)  
 Background noise: 32 dB(A)

### Crated dimensions

460 x 530 x 460 mm  
 Gross weight: 45 Kg.

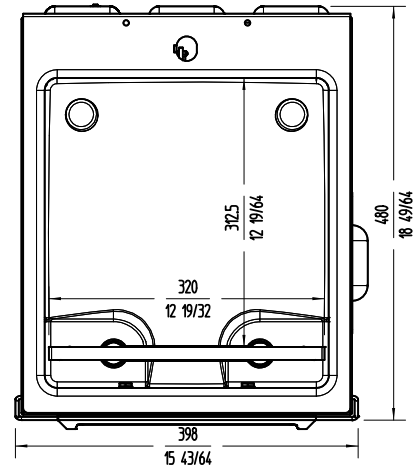
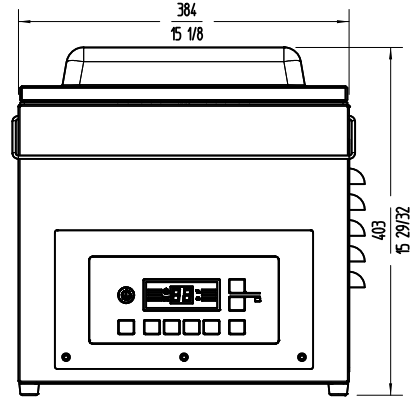
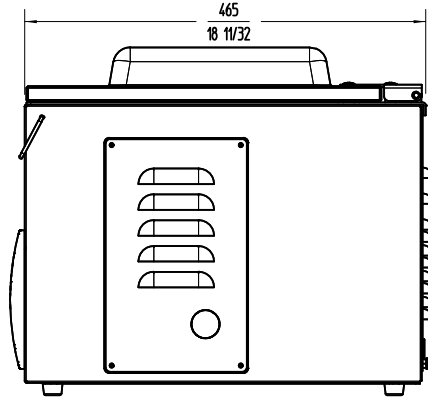

## ACCESSORIES

- Filling plates
- Liquid insert plates
- Vac-norm external vacuum kits
- Vac-norm containers
- Smooth bags for vacuum packing

FOOD PRESERVATION AND SOUS-VIDE  
 VACUUM PACKING MACHINES - "SENSOR" LINE

**sammic** | www.sammic.us  
 Food Service Equipment Manufacturer

usa@sammic.com phone +1 (224) 307-2232  
 1225 Hartrey Avenue toll free +1 844 275 3848  
 60202-1056 Evanston, IL



|          |      |
|----------|------|
| Project  | Date |
| Item     | Qty  |
| Approved |      |

product sheet  
 updated 19/04/2018