



Equipment for the Foodservice Industry

value + quality + service

Hot show cases

HCGS-1426



HCGS-1426

Features

Standard Features:

Brilliant Internal LED illumination on top LED

Adjustable temperature controller

Temperature display

Adjustable chrome plated shelves

Back hinge door

One year limited warranty parts and labour

Specifications subject to change without notice



WARRANTY
INFORMATION
One year parts
and labour.



HCGS-1426

Specifications

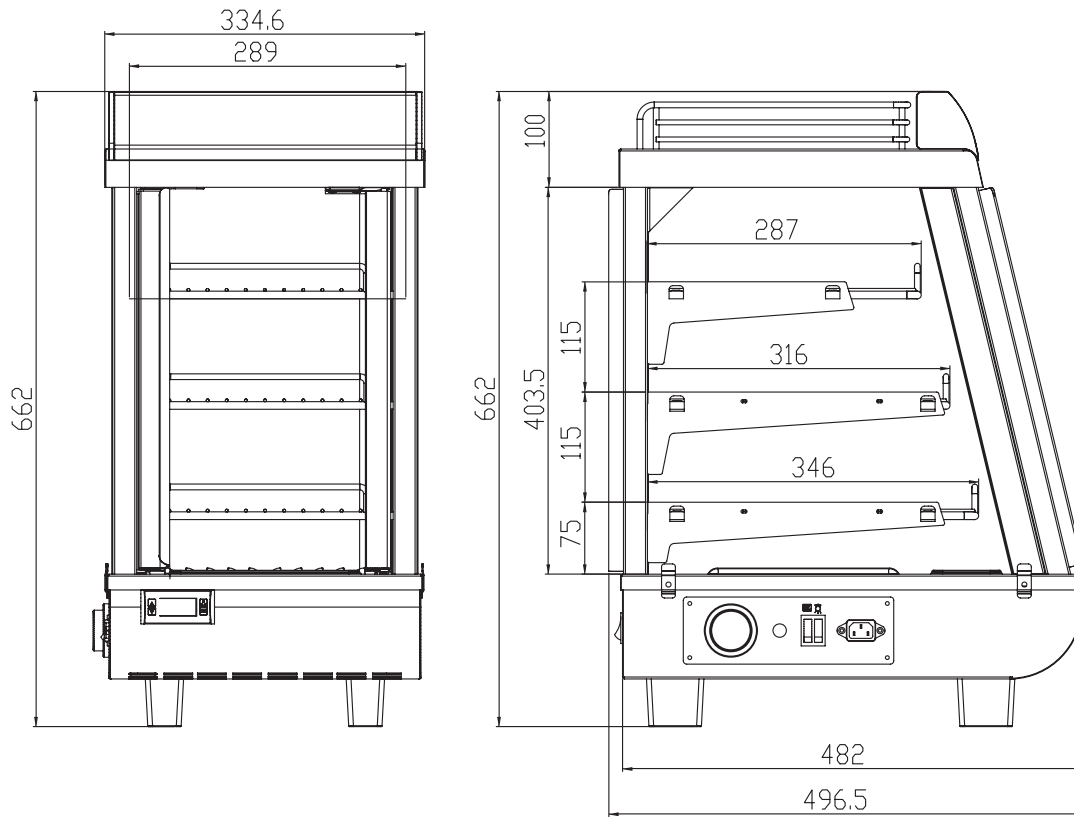

Model	Dimension			Voltage	Amps	Capacity		Net Weight	Temperature Range
	L	D	H			(L)	(Cu)		
HCGS-1426	345	484	662.5	115/60	7.6	76	21.2	30-90°C	
	13.6	19.1	26.1			2.7	46.64	86-194°F	