

TB-300E

ELECTRIC MEAT GRINDER

OPERATION MENU

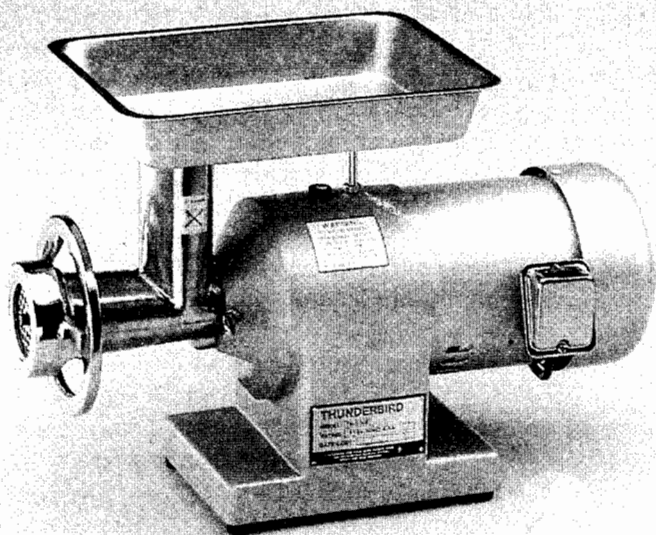

(# 12)



*** IMPORTANT INSTRUCTIONS SAVE THESE INSTRUCTIONS**

*** CAUTION: READ & SAVE THESE INSTRUCTIONS AND RETAIN THIS MANUAL FOR FUTURE REFERENCE**

IMPORTANT SAFEGUARDS

When using electrical appliances, basic safety precautions should always be followed, including the following:

1. Read all instructions.
2. To Prevent electrical hazards, do not immerse power until in water or any liquid.
3. Close supervision is necessary when any appliance is used by or near children.
4. Unplug from outlet when not in use, before putting on or taking off parts, and before cleaning.
5. Avoid contacting moving parts, Never feed food by hand. Always use food pusher.
6. Do not operate any appliance with a damaged cord set or after the appliance malfunctions, or is dropped or damaged in any manner, Return appliance to the nearest authorized service facility for examination, repair, or electrical or mechanical adjustment.
7. The use of attachments not recommended by the appliance manufacturer may cause hazards.
8. Never leave Sausage maker unattended while it is operating.
9. When operating with a multiple speed Motor Base always use the highest speed or "power" setting.
10. Do not let cord hang over edge of table or touch hot surfaces.
11. Do not use outdoors.
12. Do not use fingers to scrape food away from discharge disc while appliance is operating. Cut type injury may result.

SAVE THESE INSTRUCTIONS

SAFETY INSTRUCTIONS

THE SAFETY AND OPERATING INSTRUCTIONS SHOULD BE READ BEFORE THE MEAT GRINDER IS OPERATED AND RETAINED IT FOR FUTURE REFERENCE.

1. DO NOT USE IN DANGEROUS ENVIRONMENT. Do not use Meat Grinder in damp or wet locations, or expose them to rain. Keep work area well lighted.
2. USE RIGHT TOOL. Do not force tool for which it was not designed.
3. DISCONNECT MEAT GRINDER BEFORE SERVICING. When disassembling or cleaning machine.
4. REDUCE THE RISK OF UNINTENTIONAL STARTING. Make sure switch is "off" position before plugging in.
5. USE RECOMMENDED ACCESSORIES. The use of improper accessories may cause risk of injury to person.
6. NEVER LEAVE MEAT GRINDER RUNNING UNATTENDED. Turn power off, do not leave. Meat Grinder until it comes to a complete stop.
7. DO NOT IMMERSE POWER UNIT INTO WATER OR OTHER LIQUID.
8. Use same extension cord of Meat Grinder or heavier.
9. Use only extension cords which have plugs and receptacles accept the Meat Grinder's plug. Replace or repair damaged cords.
10. Do not abuse. Never carry product by cord or yank it to disconnect cord from receptacle. Keep cord from heat, oil and sharp edges.

CLEANING

1. DO NOT WASH THE STAND IN WATER. After use, disassemble unit and wash each part with a mild detergent and water and rinse well. The cutting knife, perforated plate, insert propeller should be washed by brush or sponge.
2. Use a soft cloth to wipe the stand. Do not wash the stand in water.
3. After washing, dry all the parts, put some oil on the surface of cutting knife, perforated plate, reassemble and store.
4. Do not use thinners or other solvents to wipe the stand and parts made of plastic.
5. Do not wash any parts in an automatic dishwasher.

HOW TO OPERATE

1. Pull as much cord as required out.
2. Make sure that the switch is in "OFF" position. Then insert the plug into a wall outlet. Use only on 110 V, 60 Hz (220 V, 50 Hz)
3. Clean meat thoroughly, thick skin should be removed. And all meat should be cut into pieces to fit into feeder opening.
4. Drop meat into opening slowly and steadily, using pusher if necessary.
CAUTION: Using excessive force on pusher may deflect pusher guide into insert cutting knife insert propeller.
5. Make sure that the cutting knife revolves properly before placing the meat in the Grinder. It is normal for residue to build up somewhat around the edges of cutter case.
6. When Grinding is completed, turn switch to "OFF" and allow cutter stop completely before disconnect cord from wall outlet and store.
7. Any servicing required should be performed by an authorized service facility.

Congratulations on owning **A THUNDERBIRD** **ELECTRIC MEAT GRINDER**

It easily and safely grinds all kinds of meat by means of perforated plate, cutting knife, insert propeller, so you can get fresh meat in a minute without losing moisture and nutrition. Enjoy tasty and healthful food such as hamburger, meat ball, sausage—etc. The only limit is your imagination! Before operating your Electric Meat Grinder, read these operating instructions thoroughly.

For operation on 110V, 60Hz A.C. only. (220V, 50Hz) only.

How to disassemble and re-assemble

Before using, disconnect cord from outlet, then remove parts one by one.

1. Loosen the bolt. (in the direction of the arrow) (Fig. 1)
2. Hold the stand, while removing the bolt. (Fig. 2)

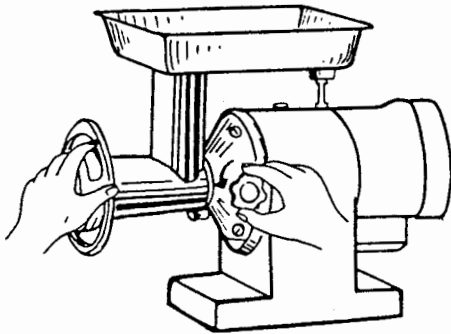

(1)

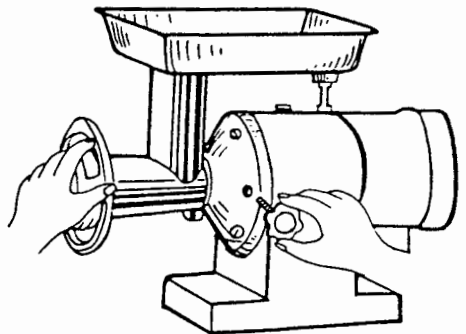

(2)

3. Loosen the screw threaded ring, then remove it. (Fig. 3)
4. Remove the perforated plate, cutting knife; insert propeller from screw threaded ring one by one. (Fig. 4)
5. Wash all parts, dry all the parts, put some oil on the surface of steel plate and cutter.

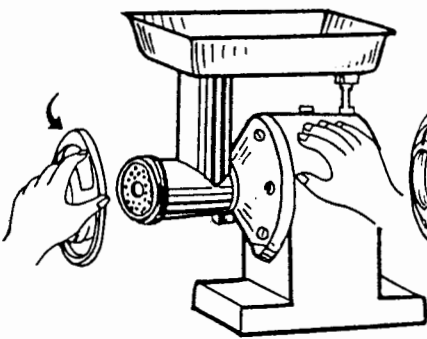

(3)

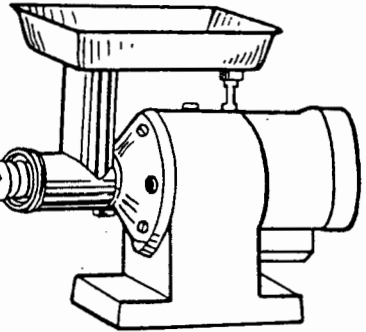

(4)

To assemble

1. Attach the perforated plate, put into the grooves of the stand. (Fig. 5)
2. Make sure that it rotates smoothly after attach cutting knife, perforated plate to the insert propeller. (Fig. 6)

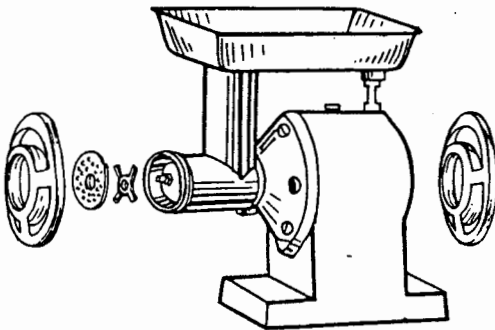

(5)

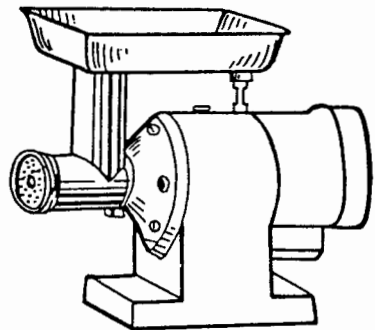

(6)

3. Make sure screw threaded ring is securely in place after tighten it. (in the direction of the arrow.) (Fig. 7)
4. Tighten bolt. (in the direction of the arrow.) (Fig. 8)

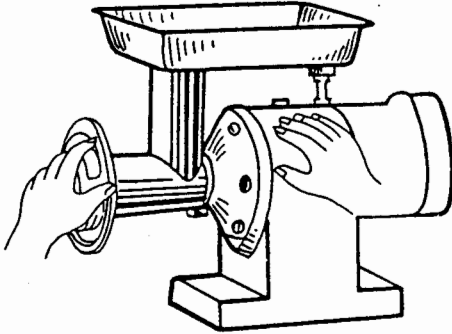

(7)

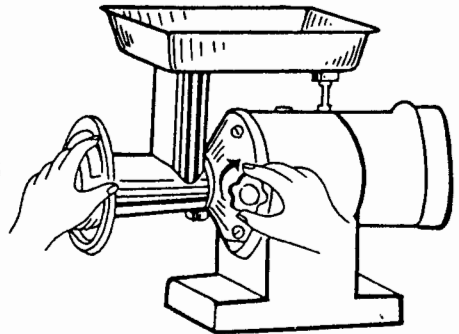

(8)