



FEATURES

- Oil lubricated rotary vane vacuum pump, nominal speed 423 cf/h (12 m³/h);
- Vacuum level control through high precision sensor;
- Maximum vacuum 99,8% (2 millibar);
- 12,4" sealing bar, easily removable for cleaning;
- Chamber in hydroformed stainless steel with constant thickness, with integrated vertical chamber for liquid packaging, easy to clean and sanitize;
- Standard inert gas injection with 2 injection nozzles and double sealing;
- Date stamps to stamp the date and lot on the bag;
- Waterproof stainless steel digital control panel, with control board and vacuum sensor protection cover;
- 20 editable user programs, with assignable names from keyboard; 5 settable display languages;
- 8 preset cycles for specific types of food to be preserved or processed ("chef" cycles), 5 deaeration cycles for solid and liquid food processing or food preservation ("chef" cycles);
- 2 generic preset cycles for preservation or sous vide cooking;
- Specific cycle for vacuum containers;
- Pump oil dehumidification cycle "H2Out"
- Menu accessible to technical assistance for parameter setting and adjustment with resettable oil change alarm;
- High-thickness blued PMMA (Plexiglass) lid with polished and rounded edges; opens automatically at the end of the cycle;
- Chromed aluminum die-cast hinges;
- Over-opening of the Plexiglas cover from 60 ° to 90 ° for easy cleaning and sanitizing of the vacuum chamber;
- Removable aluminum silicone holder bar, which allows easy cleaning and sanitizing of the vacuum chamber (patented);
- Front opening of the machine body to facilitate access to maintenance;
- High welding pressure (over 150kg with 99% vacuum) operating on the sealing bar; with thermal welding protection system;
- Standard "Easy" accessory for external vacuum in embossed bags;
- 11 PE-filling plates for product adjustment inside the vertical and the horizontal chamber and cycle speed up;

DESCRIPTION

Made of AISI304 stainless steel, the Cuisson line models features a high quality level and extreme care of every detail, which reflects into robustness, reliability and safety. They are equipped with advanced functional and technological features such as the vertical chamber, deaeration cycles, preset cycles based on the type of food to be vacuum packed, inert gas injection, double sealing. Removable silicon holder and front opening of the casing are some of the construction features designed to facilitate cleaning, maintenance and reduce operating costs.



SEALING BAR 12.4 inch
VACUUM PUMP 423 cf/h
SENSOR CONTROL

ACCESSORIES

- Bags for storage, cooking and "cook & chill"; embossed bags;
- Stainless steel cart with castors and shelf



According to:
UL197 / NSF Hygienic standards

PROJECT	DATE	APPROVED
ITEM	QTY	

VACUUM PACKAGING MACHINES CUISSON SV31N

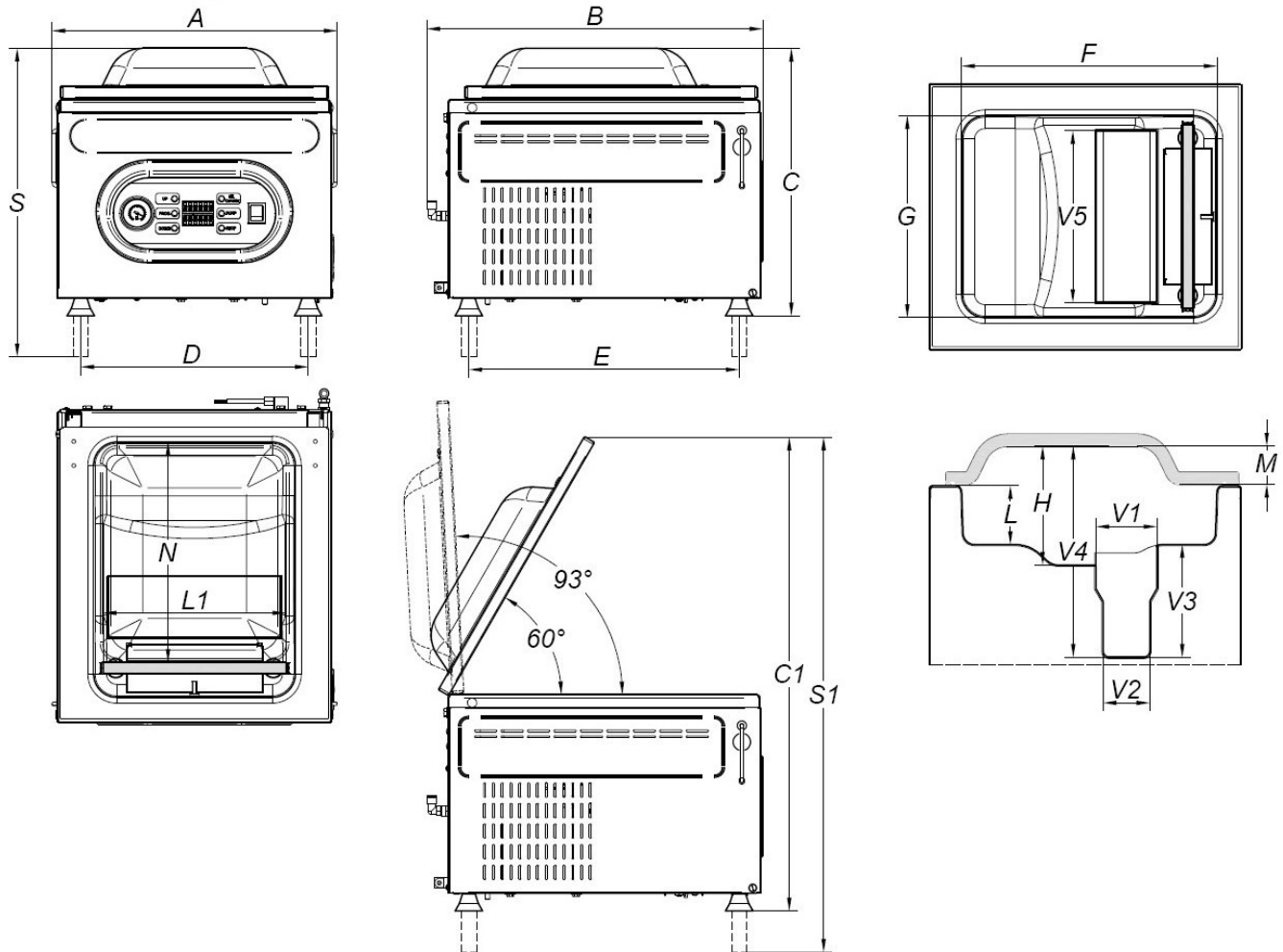

SPECIFICATIONS

Length of seal L1	inch	12,4
Nominal pump speed	cf/h	423
Final pressure	mbar	2
Horizontal chamber size (FxGxH)	inch	17,1x13,5x7,9
Vertical chamber size (V1/V2xV5xV3)	inch	3,6x11,5x7,5
Useful chamber space (N)	inch	14,8
Horizontal chamber depth (L)	inch	5,3
Vertical chamber volume	Usgal	1,368
Horizontal chamber volume	Usgal	6,6
Power	W	900
Electrical voltage/Frequency/Phases	V/Hz	110V / 60Hz / 1Ph+N+PE
Power cord and plug		98,4 inch / Nema 5
Current	A	8,18
Housing materials		AISI304 Stainless steel
Vacuum chamber material		AISI304 Hydroformed stainless steel
Lid material		PMMA (plexiglas)
Overall dimensions (AxBxC)	inch	19,1x22,5x17,9
Overall dimensions (AxBxS)	inch	19,1x22,5x20,7
Maximum height with open lid (C1)	inch	31,7
Maximum height with open lid (S1)	inch	34,5
Distance between supports (DxE)	inch	15,2x18,1
Weight (with filling plates)	lbs	130,1
Noise level	dB(A)	62
Environmental operating temperature (min-max)	°F	53,6-104