

Howard McCray

MIRAGE CURVED GLASS MERCHANDISER

- 2 rear sliding glass doors & 3 levels of display
- 2 levels with fluorescent illumination
- Reinforced steel base
- Heavy duty condensing unit for R-134a
- Reflective polarized film on rear glass doors to avoid visibility of back area & enhance exhibition area
- Polyurethane insulation with cyclopentane as blowing agent



CANADA'S LEADING DISTRIBUTOR OF FOOD STORE & BEVERAGE EQUIPMENT SINCE 1946.

1.888.443.1946

1232 - 36 Avenue NE, Calgary, AB T2E 6M8 | info@wr.ca | www.wr.ca

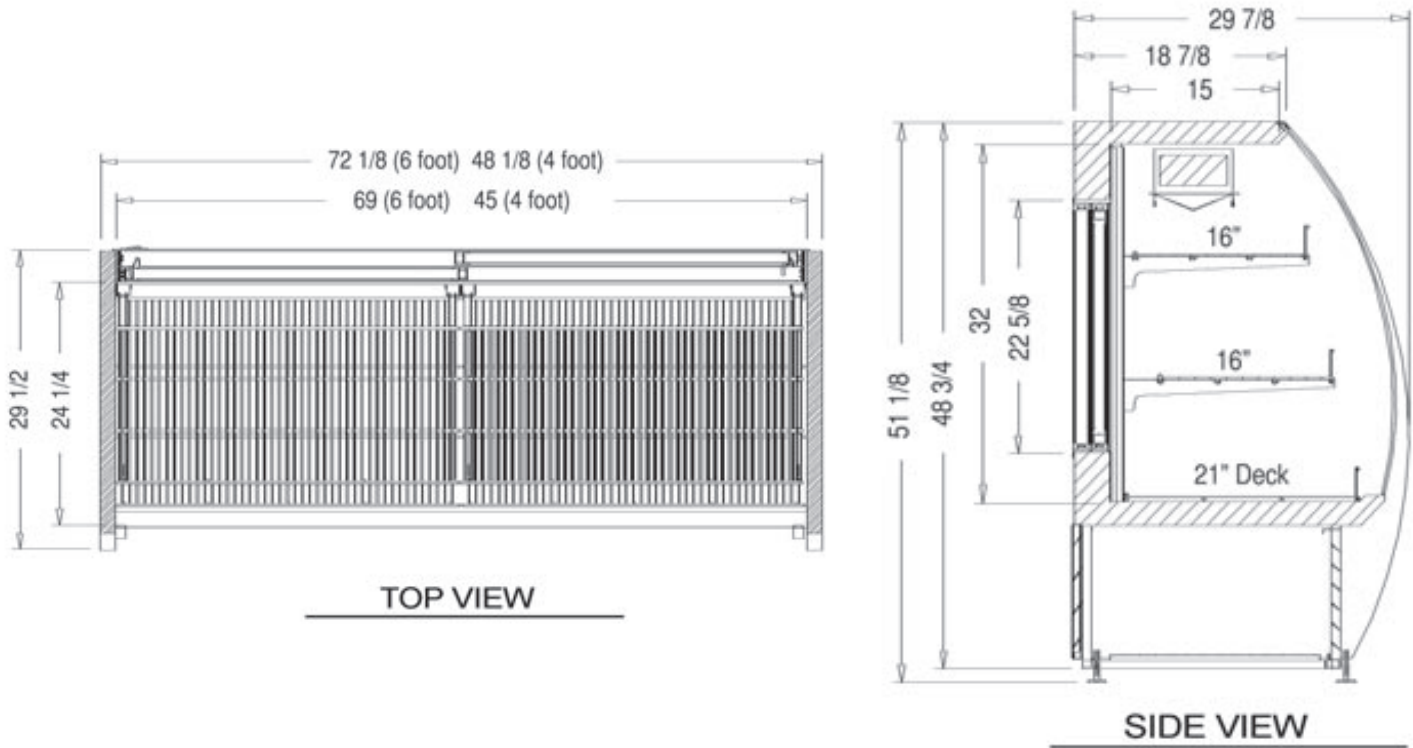

MODEL	MIRAGE-4-DC	MIRAGE-6-DC
OUTSIDE DIMENSIONS		
Depth	29.88"	29.88"
Length	48"	72"
Height	52"	52"
Door Size	23 x 21"	34 x 21"
Door Type	2 sliding	2 sliding
INSIDE DIMENSIONS		
Depth	23"	23"
Length	45"	69"
Height	32"	32"
Shelf Size	(4) 21 x 16"	(4) 33 x 16"
Main Deck Size	(2) 22 x 21"	(2) 34.25 x 21"
# of Shelves	6	6
Capacity: Cubic Foot	19	24
SPECIFICATIONS		
Operating Temperature	36°F to 40°F	36°F to 40°F
Refrigerant	134a	134a
Compressor Size HP	1/3	1/3
Voltage	115	115
Amperage	5.2	5.2
Cord and Plug	yes	yes
SHIPPING DIMENSIONS		
Depth	36"	36"
Length	54"	78"
Height	58"	58"
Gross Weight lbs.	404	476

IMPORTANT NOTE:
All refrigerated cases are designed to operate in an environment of 75 degrees and 55% relative humidity.

Specification subject to change without notice

