

ZESTO

Electric Conveyor Oven CE 4824



- * 24" (61cm) conveyor belt.
- * Stainless Steel Construction.
- * Front mount controls for easy view and access.
- * Electronic temperature control with digital read-out.
- * Variable digital speed control on conveyor belt.
- * Cook time from 1 - 20 minutes.
- * Reversible conveyor belt direction.
- * Thermally insulated for energy efficiency.

- * High velocity precision targeted air flow distribution panels for consistent repeatable baking results.
- * Stackable (up to 2 units high).
- * Super efficient electric tubular elements.
- * Removable front panel, crumb tray, top and bottom air flow distribution panels for easy cleaning.
- * Legs with locking casters (17", 23" or 29" available)



Removable panels for easy cleaning
"U.S." Patent # 6,192,877 B1

Ideal for a variety of cooking applications including pizza, seafood, omelettes and other egg dishes, pre-cooked meats, cookies, bakery products, pita breads, heating plated Mexican food and hot submarine sandwiches.

Electric Conveyor Oven

CE 4824



Conforms to: ANSI / UL Std. 197
Conforms to: CSA C22.2 Std. 109

Conforms to:
Std. NSF-4

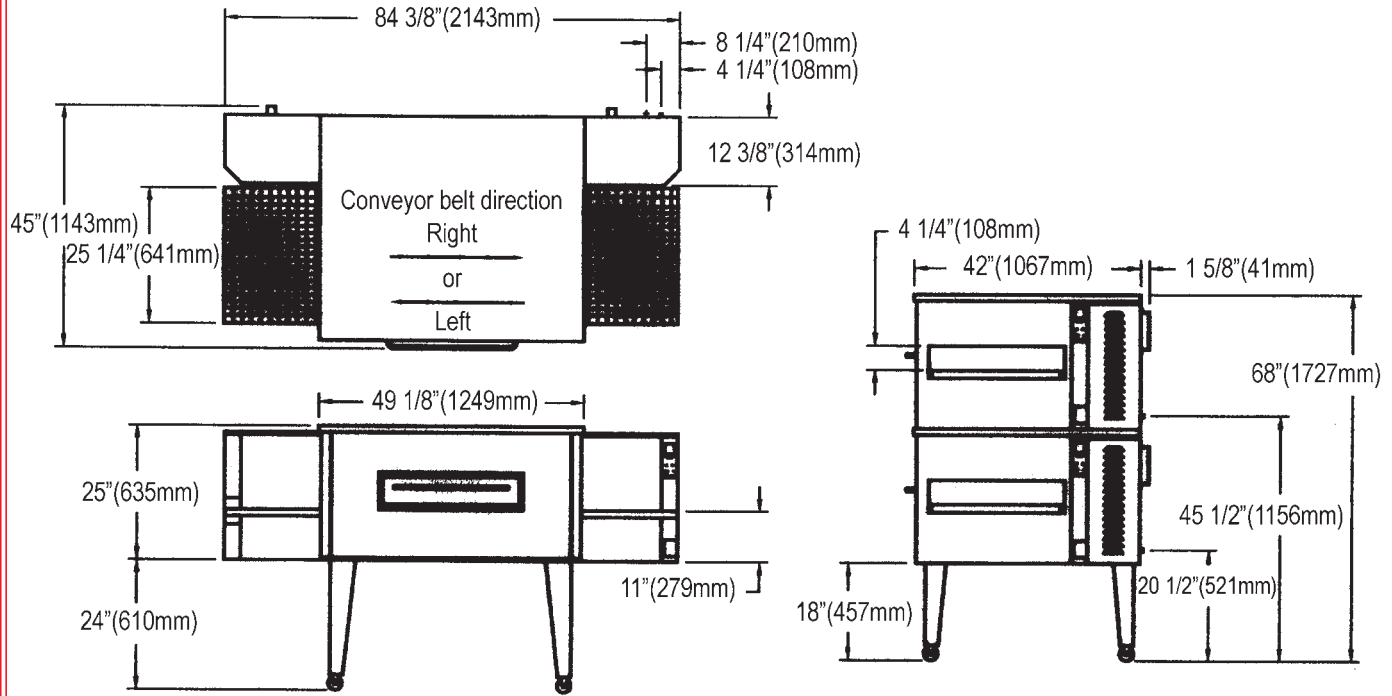

Approximate production per hour / per section / bake time in minutes (4824)

Pan diameter	5 min	6 min	6.45 min	7 min	7.5 min	8 min	9 min
6" (15 cm)	382	318	295	272	254	238	211
8" (20 cm)	214	178	165	152	142	132	118
10" (25 cm)	136	113	105	96	90	84	74
12" (30 cm)	94	78	72	66	62	58	51
14" (35 cm)	69	56	52	49	45	42	37
16" (40 cm)	52	43	40	36	34	31	29

Cooking Chamber 48" (121.9 cm) long X 24" (61 cm) deep

Model	Electric elements/kw	Exterior dimensions	Length of belt	Voltages / Amps	Ship wt..
CE 4824	(9 X 3.5 kw) = 31.5 kw	84"L x 42"D 213cm x 107cm	84"L x 24"D 213cm x 61cm	220-240v / 1 ϕ (151 - 139 amps) 208-220v / 3 ϕ (95.4 - 90.7 amps) ** 400v / 3 ϕ (53.5 amps) ** 480v / 3 ϕ (45.9 amps) ** 600v / 3 ϕ (38.3 amps) ** Optional at extra cost	995 lbs 451 kg

Available in 50 or 60 cycles. Amperage could vary if input volts are not the same as indicated.

ZESTO FOOD EQUIPMENT MANUFACTURING INC.
MANUFACTURIER D'EQUIPEMENT EN ALIMENTATION INC.
6450 HUTCHISON, MONTREAL, QC, CANADA H2V 4C8
TEL(514)278-4621 FAX(514)278-4622
e-mail info@zesto.ca www.zesto.ca

SPECIFICATIONS SUBJECT TO CHANGE WITHOUT NOTICE.

LES SPÉCIFICATIONS SONT SUJETS À CHANGEMENT SANS AVIS.