



XL-300
HI-SPEED COOK OVEN



- Combines proven microwave and forced air impingement technologies to cook up to 10X faster than a conventional oven.
- Convection heat is forced through a specially designed impingement plate with strategically placed holes, causing the air to spin and focus the heat.
- Fully programmable touchscreen can store up to 100 programs for simple menu selection and consistent food quality.
- Compact space-saving design allows units to be placed over or under a counter, or double stacked.
- Built-in catalytic converter removes smoke, odor and grease laden vapor - eliminating the need for an expensive exhaust hood.
- Perfect for preparing individual á la carte servings.
- Ideally suited for a limited service menu featuring quick service and convenience items.
- Front accessible USB port provides easy control updating and menu recipe program management.

The XL-300 is a hi-speed cook oven with an internal catalytic converter, forced impingement convection and single magnetron microwave technology. Heavy-duty, solid stainless steel construction and insulated cooking chamber. Touchscreen control with graphical display operates in English, French, and Spanish - stores up to 100 recipes, can be organized in groups or marked as favorites. Time control key has a maximum of 9 minutes and 59 seconds. Baking temperature has a maximum of 536°F (280°C). Variable fan speed can be adjusted from 10% to 100% in increments of 10%. Microwave power can be adjusted from 0% - 100%. Oven includes a metal wire shelf, large metal peel, and 4" (102mm) adjustable legs.

MODEL XL-300: Hi-Speed Cook Oven



FACTORY INSTALLED OPTIONS

Electrical Choices:

- 208-240V, 1ph, 60Hz
- 208-240V, 1ph, 50Hz

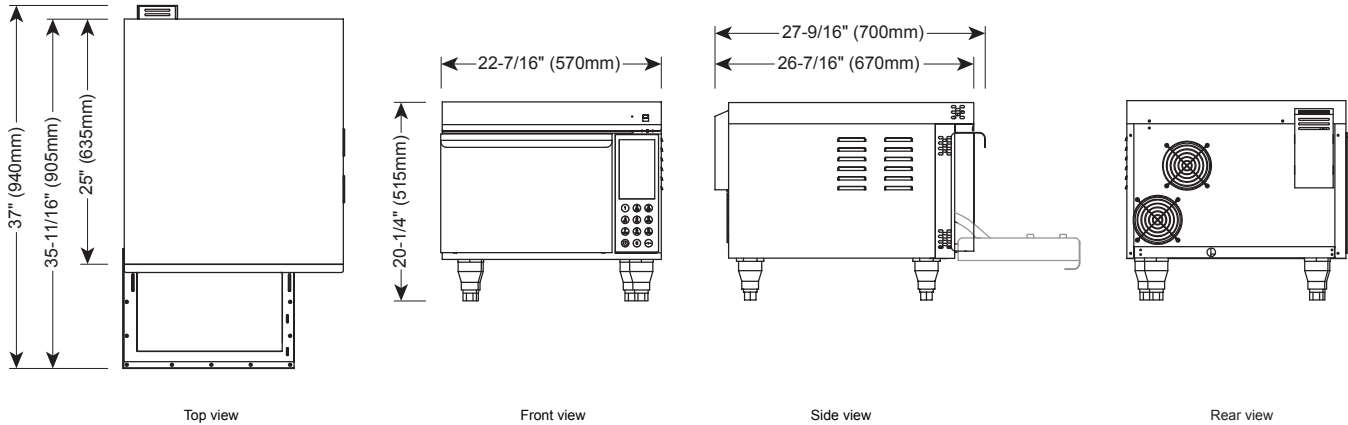

ELECTRICAL (DEDICATED 20AMP CIRCUIT REQUIRED) Connections to the internal transformer must be made by an authorized service technician.						
MODEL	VOLTAGE	PH	HZ	AMPS	kW	CORD & PLUG
XL-300	208 - 240	1	60	16	3.3	 NEMA L6-20P - US ONLY
	208 - 240	1	50	16	3.3	CORD ONLY - NO PLUG

DIMENSIONS: H x W x D
EXTERIOR: 20-1/4" x 22-7/16" x 27-9/16" (515mm x 570mm x 700mm)
INTERIOR: 6-11/16" x 13-3/16" x 12-5/8" (170mm x 335mm x 320mm)

PRODUCT CAPACITY
0.62 CUBIC FEET (0.017556M ³) 12" (305mm) DIAMETER ROUND PIZZA

WEIGHT	
NET WEIGHT:	135 lbs (61 kg)
SHIP WEIGHT:	183 lbs (83 kg)
CRATE DIMENSIONS: (L x W x H)	32" x 26" x 25" (813mm x 660mm x 635mm)

ACCESSORIES	
<input type="checkbox"/> Baking Stone	ST-36549
<input type="checkbox"/> Baking Mat	SH-36546
<input type="checkbox"/> Food Tray	TY-36592
<input type="checkbox"/> Panini Griddle	PN-36595
<input type="checkbox"/> Heat Shield	1015658
<input type="checkbox"/> Stacking Panel	PE-37101
<input type="checkbox"/> Stacking Hardware: XL-300 over a 750-S, 750-TH/II, 750-TH/III, 1000-S, 1000-TH/II, 1000-TH/III, or QC2-3	5019677
<input type="checkbox"/> Combitherm® Cleaning Liquid — SPECIALLY FORMULATED FOR COMBITHERM OVENS TWELVE (12) CONTAINERS/CASE, 1 QUART (C. 1 LITER) EACH [SPECIAL HANDLING REQUIRED]	CE-24750

CLEARANCE REQUIREMENTS	
LEFT, RIGHT	4" (102mm)
REAR (WITHOUT OPTIONAL HEAT SHIELD)	11-13/16" (300mm)
REAR (WITH OPTIONAL HEAT SHIELD)	0" (0mm)

INSTALLATION REQUIREMENTS	
Unit must be installed level and must not be installed in any area where it may be directly affected by steam, grease, dripping water, high temperatures, or any other severely adverse conditions.	
Environment temperature is not to exceed 104°F (40°C).	
Service access is on the right side and must be accessible.	
Electrical connections to the internal transformer must be made by an authorized service technician.	

