



HID525 - Touch-Free Ice & Water Dispenser

Nugget Ice Machine / Dispenser



HID525A-1 with optional KLP24A legs

Sealed, maintenance-free bearings ensure maximum reliability and contribute to a long machine life

The Meridian® Difference

Sanitation:

- Touch-free, infrared dispensing of ice and water eliminates the need to physically touch the dispenser for more sanitary operation
- AgION® and other antimicrobial compounds are molded into key components to help inhibit the growth of microbes, bacteria, mold and algae
- Fully removable bin, spouts, air filter, sink, and grill allow for easy cleaning and maintenance
- Sealed refrigeration system minimizes outside airborne contamination
- Front accessible, removable air filter makes cleaning more convenient

Reliability & Ease of Use:

- Sealed, maintenance-free bearings reduce preventative maintenance and ensure maximum reliability
- Produces Scotsman's chewable H² Nugget Ice which is slow-melting and designed for reliable dispensing
- Space-maximizing design – the industry's smallest operational footprint relative to capacity, featuring specially designed contoured sides for enhanced breathability
- SmoothStream™ water dispensing technology reduces splashing to keep the machine and surrounding areas clean
- Unit-specific QR code for quick access to service manuals and warranty history
- Durable stainless-steel evaporator and exterior panels, plus larger sink opening and dispensing area
- Enhanced service features - Intuitive LED diagnostic lights reduce service time and convenient USB drive allows for fast software updates
- Industry-leading energy and water efficiency along with quieter operation

HID525 - Touch-Free Ice Machine / Dispenser



Touch-free infrared sensor dispensing option, providing more sanitary operation



User controlled antimicrobial push-button dispensing option, providing quick and efficient operation



24 Hour Volume Production

Air Cooled		Water Cooled	
70°F/21°C 50°F/10°C	Air Water	90°F/32°C 70°F/21°C	70°F/21°C 50°F/10°C
500/227 lb/kg		380/166 lb/kg	500/227 lb/kg
			400/181 lb/kg



Specifications

Model Number	Condenser Unit	Dispensing Method	Storage Capacity lb/kg	Basic Electrical Volts/Hz/Phase	Max. Fuse Size or HACR Circuit Breaker (amps)	Min. Circuit Amps	Energy Consumption kWh/100 lb 90°F(32°C)/70°F(21°C)	Water Usage Gallons/100 lb (liters/45.4 kg)	
								Potable 90°F(32°C)/70°F(21°C)	Condenser 90°F(32°C)/70°F(21°C)
HID525AX-1	Air	Touch-Free Sensor	25/11.3	115/60/1	15	Cord	4.18	12/45.5	-
HID525ABX-1	Air	Button Activated	25/11.3	115/60/1	15	Cord	4.18	12/45.5	-
HID525AWX-1*	Air	Touch-Free Sensor	25/11.3	115/60/1	15	Cord	4.18	12/45.5	-
HID525WX-1	Water	Touch-Free Sensor	25/11.3	115/60/1	15	Cord	3.53	12/45.5	120/454.3
HID525WBX-1	Water	Button Activated	25/11.3	115/60/1	15	Cord	3.53	12/45.5	120/454.3

*Wall mount configuration. Does not have or accept a drip tray. Unit designed to be installed over existing sink.



H²Nugget Ice

Chewable, slow-melting ice that allows for more reliable dispensing.

3/4" x 5/16" x 3/8"
(1.9 x 0.8 x 0.95 cm)



Certification



Warranty

- 3 years parts and labor.
- 5 years parts on the compressor and condenser.
- Warranty valid in North, South & Central America for commercial installations.
- Contact factory for warranty in other regions.
- Residential Applications: 1 year parts and labor



HID525 - Touch-Free Ice & Water Dispenser

Nugget Ice Machine / Dispenser

Without Wall Mount: HID525A(B) & HID525W(B)

Installation Note: Allow 6" space at left, back and right side for ventilation and utility connections.
All models include 7.5' power cord with NEMA 5-15P plug

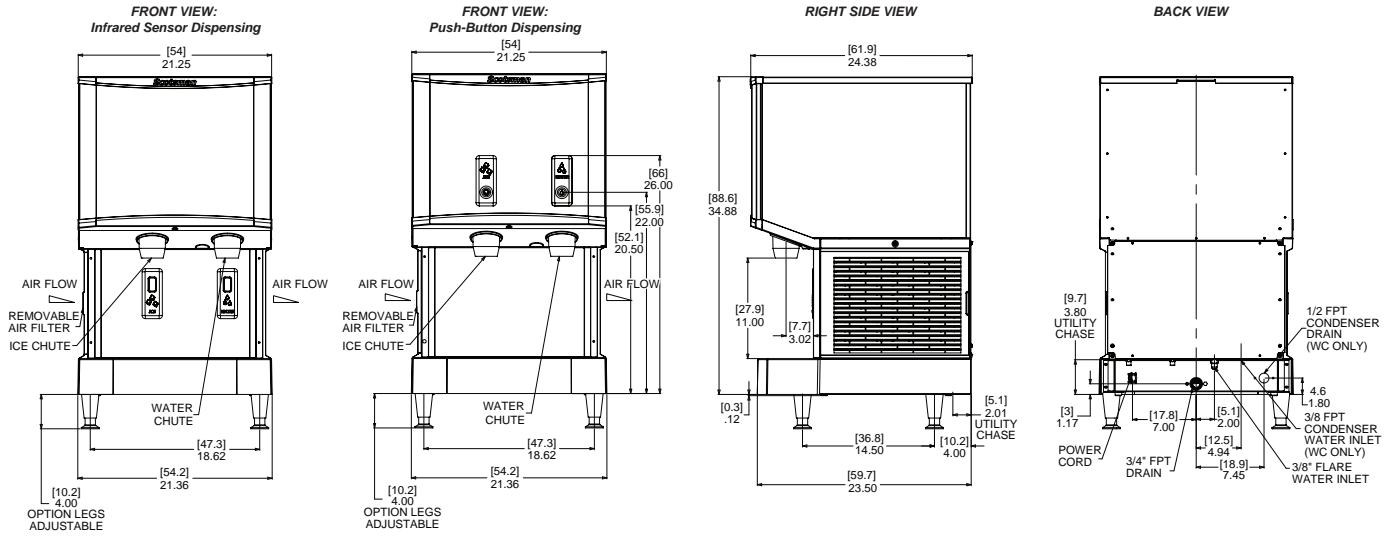

With Wall Mount: HID525AW

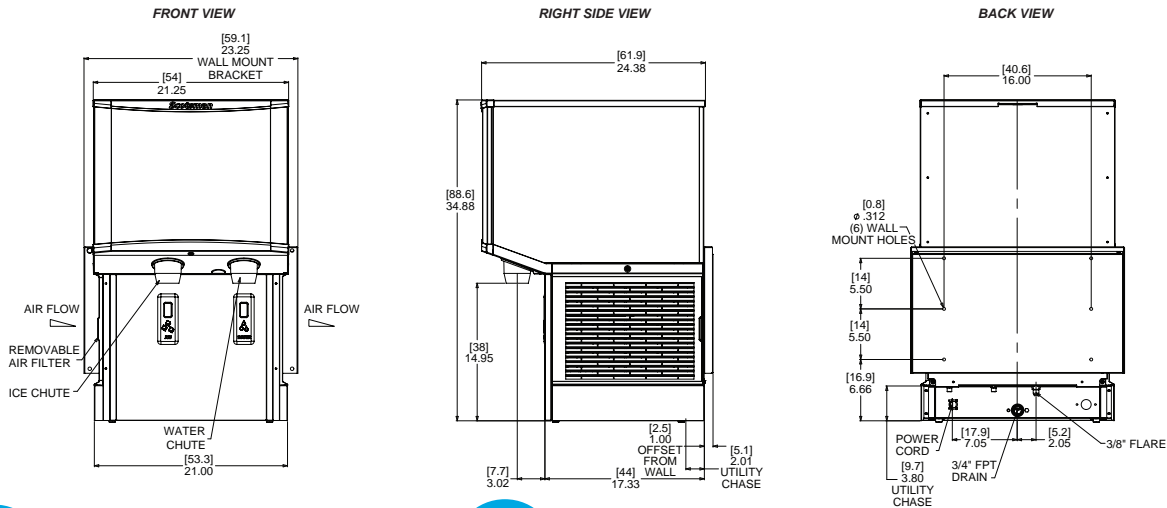

HID525 - Touch-Free Ice Machine / Dispenser



All Models

Dimensions (W x D x H):

Unit:

- HID525A(B)X-1: 21.25" x 24.38" x 35"
- HID525AWX-1: 23.25" x 24.38" x 35"
- HID525W(B)X-1: 21.25" x 24.38" x 35"

Shipping Carton:

- HID525A(B)X-1: 24.25 x 27.13 x 41.5
- HID525AWX-1: 24.25 x 27.13 x 41.5
- HID525W(B)X-1: 24.25 x 27.13 x 41.5

Shipping Weight: HID525A(B)X-1: 208 lb / 95 kg
HID525AWX-1: 213 lb / 97 kg
HID525W(B)X-1: 208 lb / 95 kg

BTUs per hour: 6,800

Refrigerant: R290

Refrigerant Charge (oz): 5.0



Accessories

Model Number Description

- | Model Number | Description |
|--------------|--|
| KLP24A | 4" Adjustable legs, box of 4, plastic with metallic foot. |
| HST21-A | Machine stand for HID525 and HID540, with locking reversible door and shelf. |
| HST21B-A | Machine stand for HID525 and HID540, basic version. |

Scotsman recommends all ice machines have water filtration. See Scotsman water filter specification sheet for details.



Operating Requirements

	Minimum	Maximum
Air Temperatures	50°F (10°C)	100°F (38°C)
Water Temperatures	40°F (4.4°C)	100°F (38°C)
Potable Water Pressures	20 PSIG (1.4 bar)	80 PSIG (5.5 bar)
Electrical Voltage	-5%	+10%

Specifications and design are subject to change without notice.