

NCD-32-CD

REFRIGERATED COUNTERTOP DISPLAY CASE

Ideal for restaurants, cafés, and bakeries



FEATURES

Double pane glass on all 4 sides

LED interior lighting

On/off switch at the rear

Digital temperature control

Rear sliding glass doors

Shelving with adjustable angles

Vents to eliminate condensation

SPECIFICATIONS

Capacity (Cu. ft)	6.92
Capacity (Liters)	196
Exterior Dimensions (in)	31 1/4" x 22 1/3" x 34 3/8"
Package Dimensions (in)	33 1/4" x 24 7/8" x 37 3/8"
Net Weight (kg/lbs)	64 / 141.1
Nbr of Shelves	3
Door(s)	Sliding at the back
Temperature Range (°C)	2 TO 12°C
Ambiant Temperature	≤ 30°C
Ambiant Humidity	≤ 55%
Refrigerant (CFC-Free)	R290
Amperage (A)	3.90A
Plug Type	NEMA 5-15P

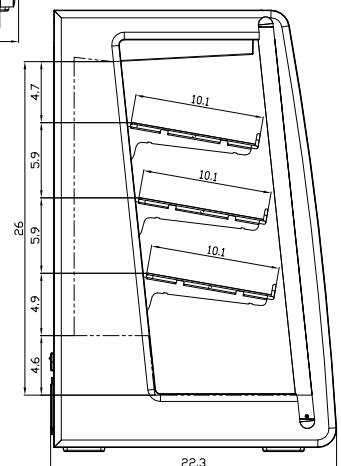
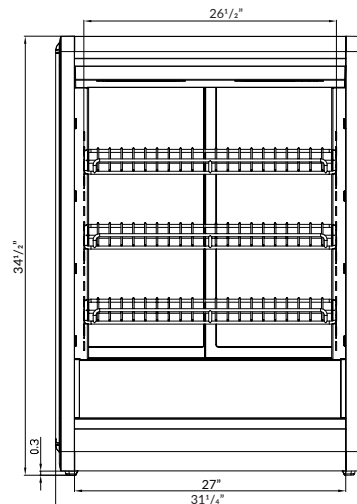

*Design and specifications may change without prior notice for product improvement

CUSTOMER SUPPORT



1-800-567-3620



NEWAIRREFRIGERATION.CA



2025