



VERSA HEAT

HSM36 SERIES SALAMANDER 36-INCHES



WARRANTY:
LIMITED ONE YEAR PARTS
AND LABOUR
**SPECIFICATIONS SUBJECT TO
CHANGE WITHOUT
NOTICE.**



HSM36-N | HSM36-P 36" SALAMANDER AVAILABLE IN NATURAL GAS OR PROPANE

- Stainless Steel front and Sides
- 35,000 BTU Infrared burner (NG), 32,000 BTU (LP)
- Standing pilot ignition system
- Full-width broiler pan
- 3/4" rear gas connection with regulator
- 3-position adjustable spring-balanced rack
- Ball grip handle on adjustable rack for ease and comfort
- 4" adjustable height, non-skid SS Legs included for countertop operation
- Gas pressure regulator is supplied with the unit
- NG or LP gas conversion kit included
- Ready to mount over any 36" to 60" ranges **ONLY** available for purchase: **PVHA010116**
- Direct wall mounting available for purchase: **PVHA010114**
- Gas hose kit available for purchase: **SIF-HG-4D-48SEL**

ADDITIONAL IMAGES



MODEL DESIGNATIONS



ADDITIONAL RESOURCES

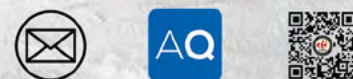

DIMENSIONS

Code	Dimensions	Width		Depth		Height		Weight	
		Inches	mm	Inches	mm	Inches	mm	Lbs	KG
HSM36-N	Exterior	36.0	914.0	23.9	608.0	17.7	450.0	127.6	58.0
HSM36-P	Shipping	39.0	990.0	26.4	670.0	23.6	600.0	280.7	127.6

TECHNICAL

Code	Gas Type	# of Burners	BTU per Burner	Total BTU Output	Operating Gas Pressure	Conversion Kit INCL.
HSM36-N	NG	1	35000	35000	5.0"W.C	Yes
HSM36-P	LP	1	32000	32000	10"W.C	Yes

LINE DRAWINGS

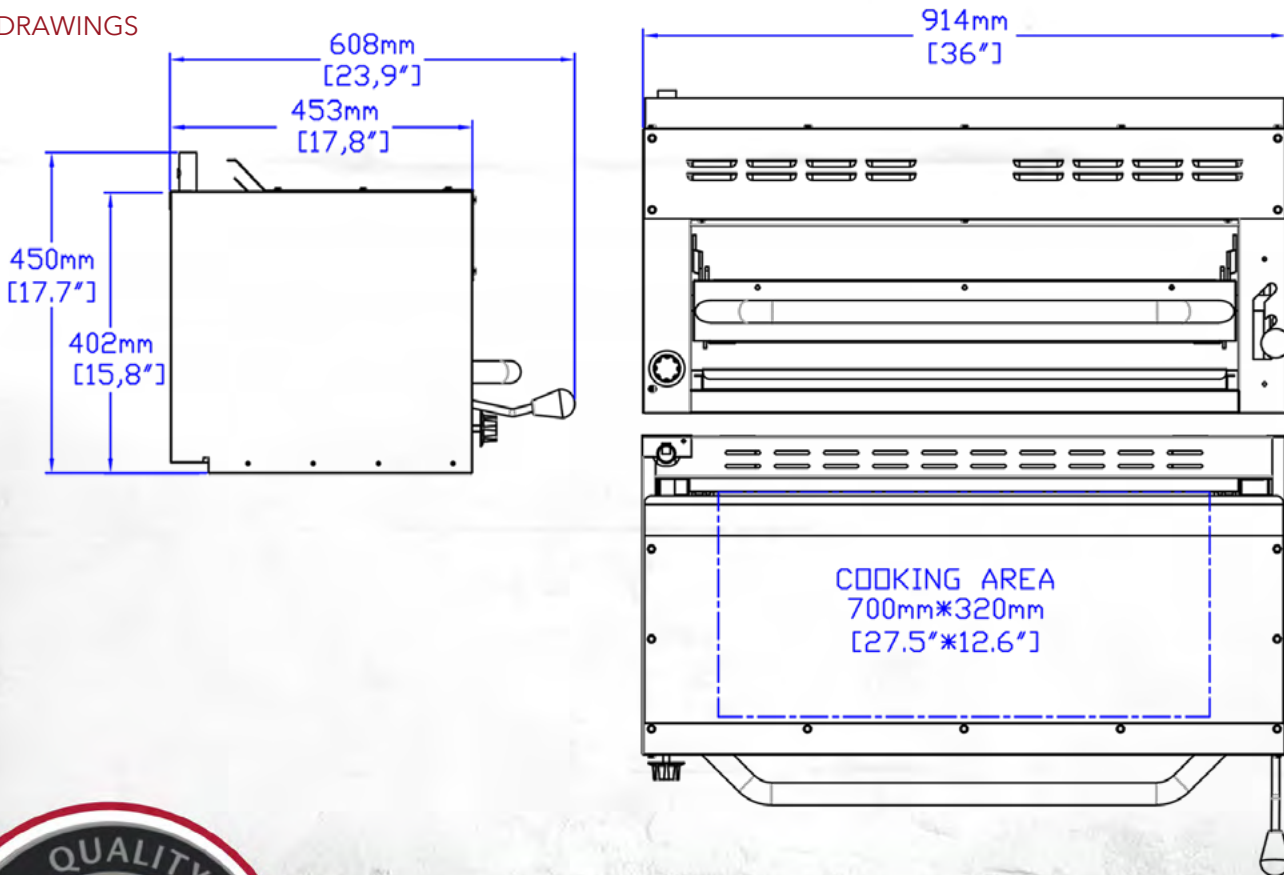

EFI Sales Ltd.
 Toronto Office & DC
 515 Hanlon Creek Blvd.
 Guelph, ON, N1C 0A1

EFI Sales Ltd.
 Vancouver Office & DC
 26895 Gloucester Way
 Langley, BC, V4W 3Y3

(888) 565-9920 Toll Free
 (519) 822-1895 Toronto
 (604) 607-8850 Vancouver