



Equipment for the Foodservice Industry
value + quality + service

54" Ice Cream Freezer 2 Glass Door S/S

Model No:
F12-54GDSVC



F12-54GDSVC

Features

Features:

- Bottom mount compressor units
- Environmentally friendly R290 refrigerant
- Led lighting interior display system
- Dixell digital temperature control system
- Heavy duty Embraco compressor
- Self-closing and stay open door
- Efficient refrigeration system
- Recessed door handle
- Standard safety door lock
- Magnetic door gaskets
- Pre-installed casters
- Pre-installed shelves

Warranty:

- Two year parts and labour; Five years on compressor. For full warranty details visit <https://www.efifoodequip.com/warranty-info.php>



FI2-54GDSVC Specifications

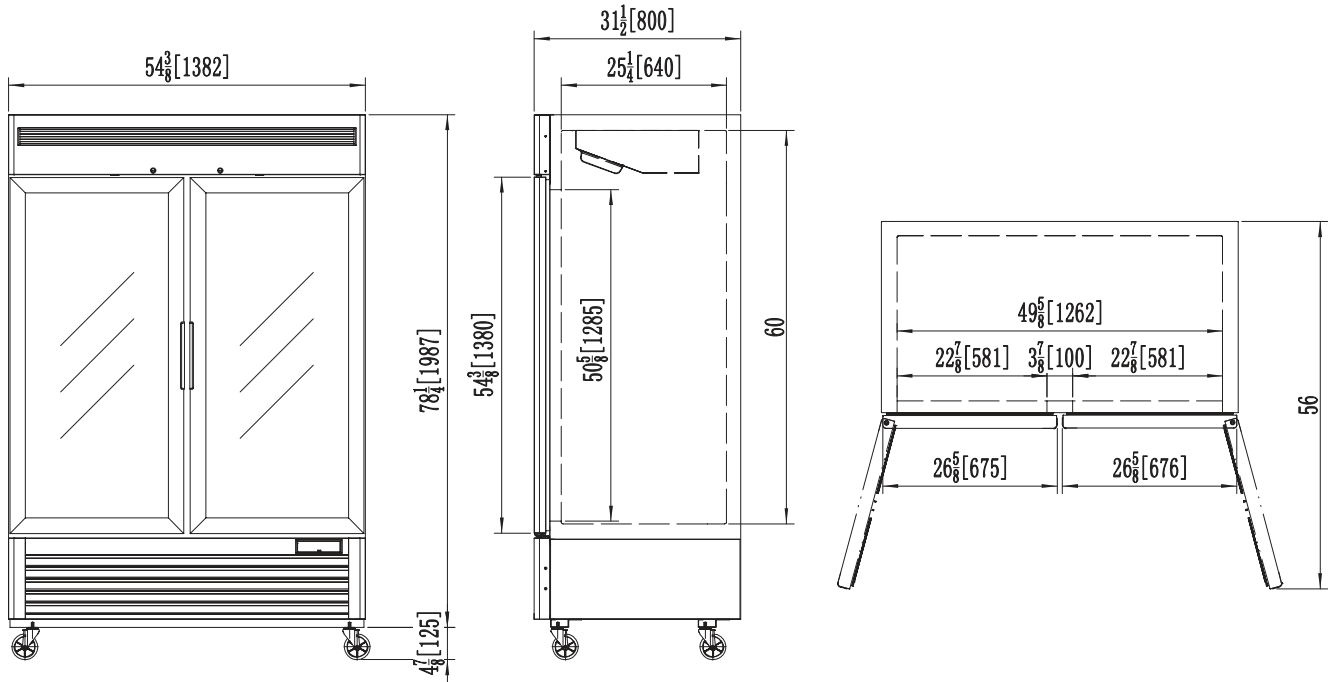

Model	Shelves	Dimension (mm) (inch)			Watts	Voltage	Amps	Capacity (L) (Cu Ft.)	Net Weight (KG) (LBS)	Temperature Range
		W	D	H						
FI2-54GDSVC	8	1382	800	2135	1360	115V/208-230V	15	1240	226	-7.6 ~ -18.4°F
		54.4	31.5	84.1						

Equipped with one NEMA L14-20P plug



Shipping Information

Crate Dimensions (mm) (inch)			Net Weight (KG) (LBS)	Gross Weight (KG) (LBS)
W	D	H		
1435	862	2154	226	251
56.5	33.9	84.8	498	553

Specifications subject to change without notice.



EFI Sales Ltd.
Toronto Office
515 Hanlon Creek Blvd
Guelph, ON N1C 0A1

EFI Sales Ltd.
Vancouver Office
26895 Gloucester Way
Langley, BC V4W 3Y3

Distribution Facilities:
Toronto, ON
Langley, BC

(888) 565-9920 Toll Free
(519) 822-1895 Toronto
(604) 607-8850 Vancouver
info@efifoodequip.com
www.efifoodequip.com